



Marko Juras

FAIR REALTY



markojuras@shaw.ca markojuras.com

Office: 778-430-2228 Mobile: 250-380-8297
Fax: 778-430-2228

1212 Queens Ave

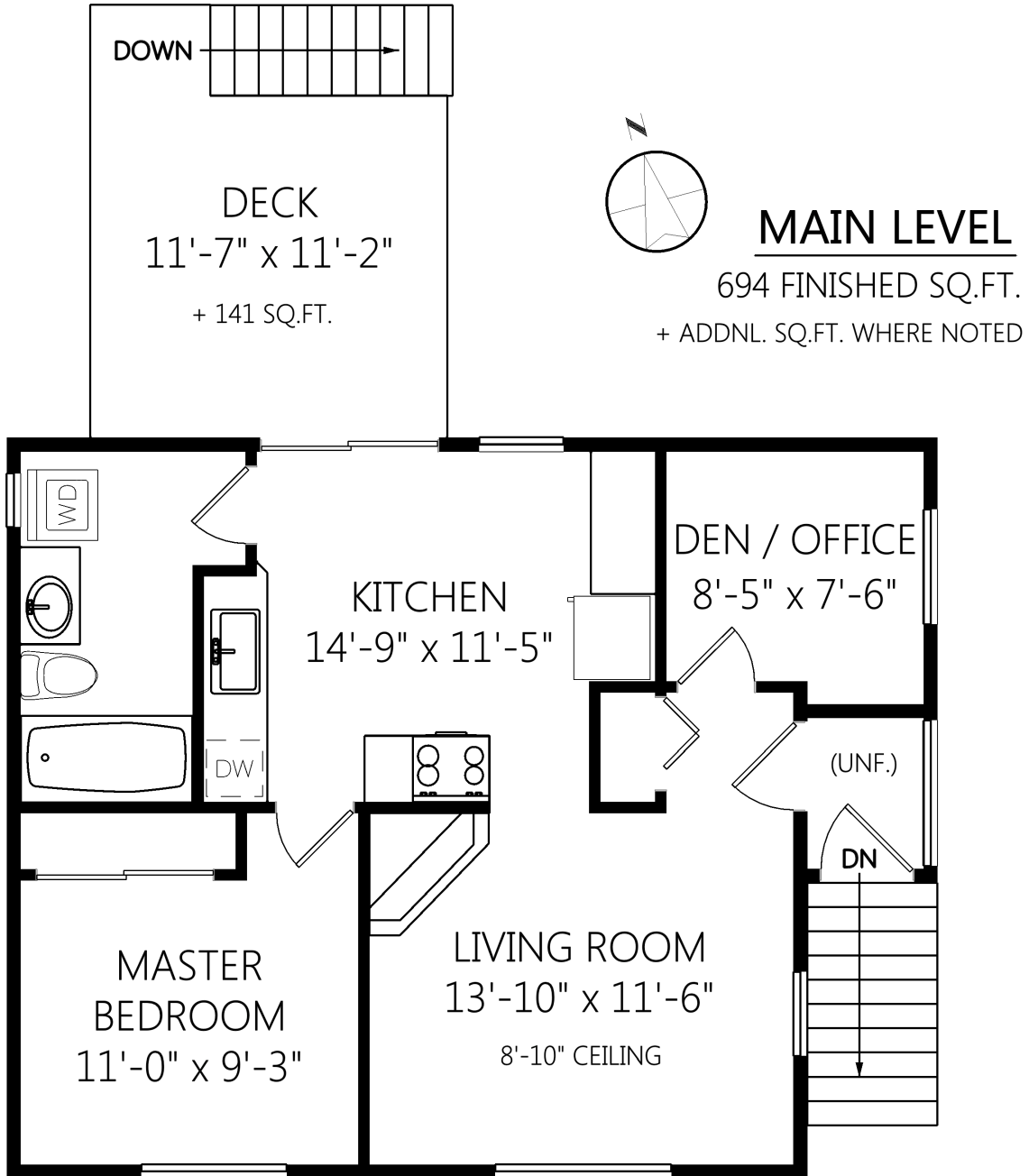

	Fin. Sq.Ft.	UnFin. Sq.Ft.	Total Sq.Ft.
Main Level	694	0	694
Lower Level	631	0	631
Total	1325	0	1325

Shown length and width dimensions are approximate.
Area sq.ft. is representative of the on-site measurements. (1" accuracy)



Figures, Calculations, and Representations are for indicative and promotional purpose only.
VI Standard Real Estate Services Inc. will not be liable for any damages of any kind arising from the mis-use of this information.



Marko Juras

FAIR REALTY



markojuras@shaw.ca markojuras.com

Office: 778-430-2228

Mobile: 250-380-8297

Fax: 778-430-2228

1212 Queens Ave

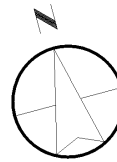
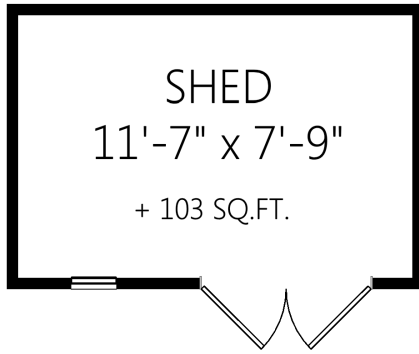

LOWER LEVEL

631 FINISHED SQ.FT.

+ ADDNL. SQ.FT. WHERE NOTED

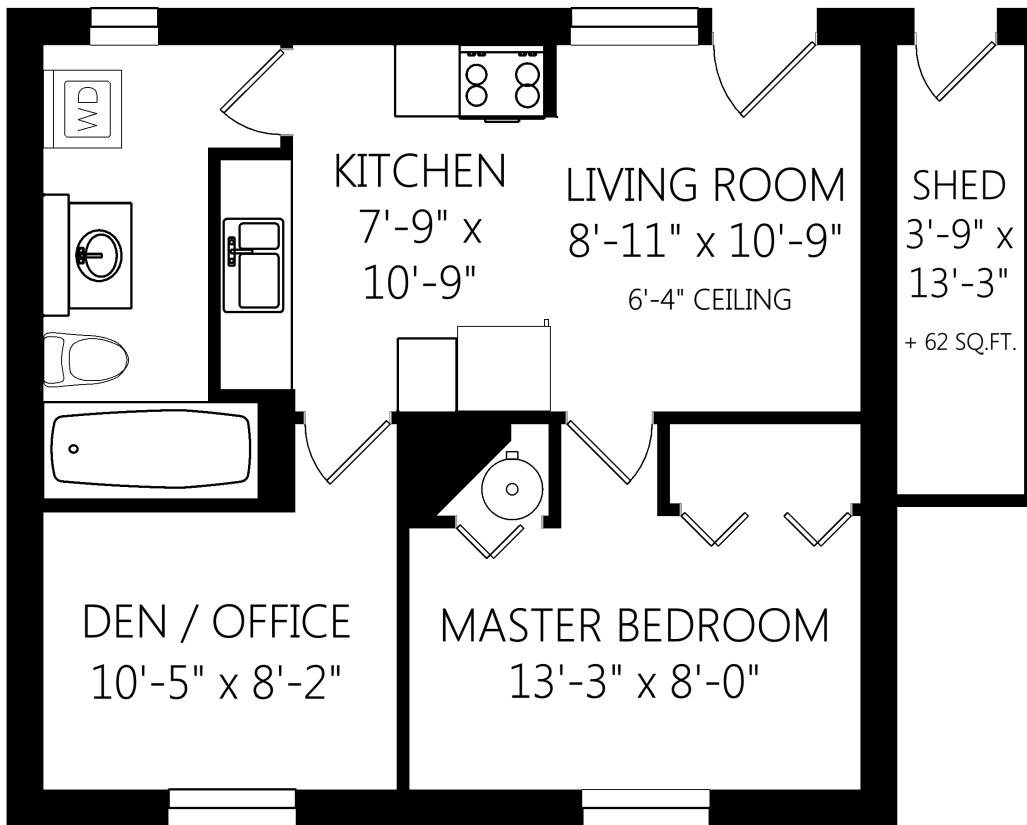

	Fin. Sq.Ft.	UnFin. Sq.Ft.	Total Sq.Ft.
Main Level	694	0	694
Lower Level	631	0	631
Total	1325	0	1325

Shown length and width dimensions are approximate. Area sq.ft. is representative of the on-site measurements. (1" accuracy)



Figures, Calculations, and Representations are for indicative and promotional purpose only. VI Standard Real Estate Services Inc. will not be liable for any damages of any kind arising from the mis-use of this information.